

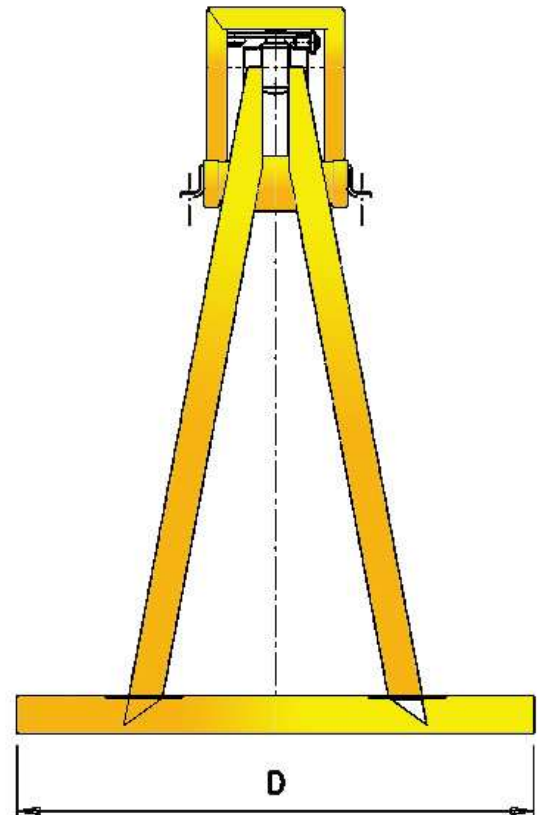

AB600, AB601, AB602

PLEASE ALLOW FOR ROTATOR

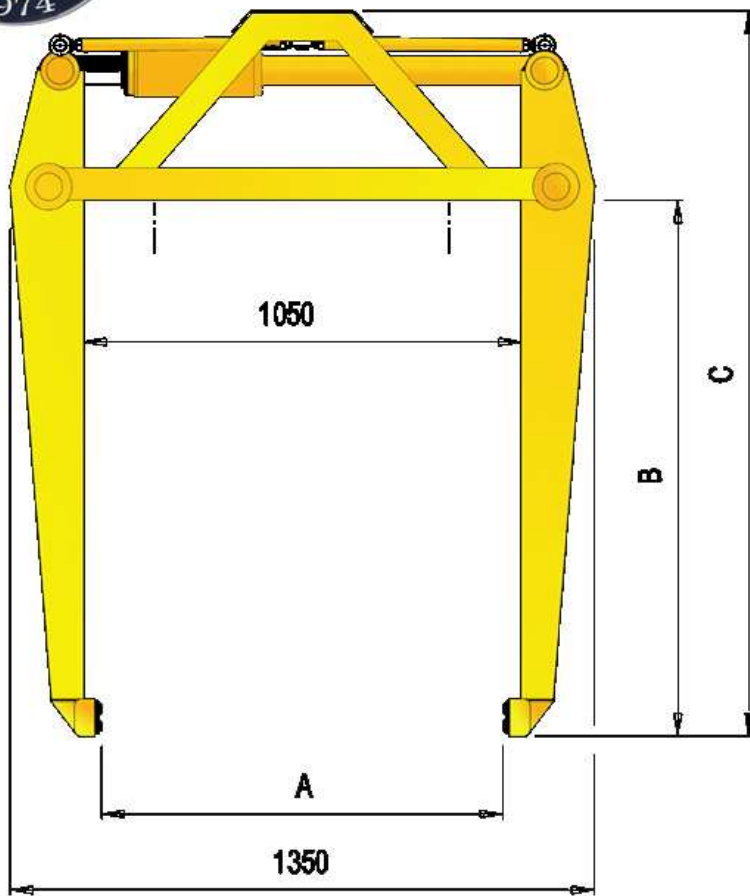

MODEL

IDEAL width of stack across A.

A MAX

A MIN

B

C

D

Recommended brick stack size :

max width

max length

max height

Cylinder ports

Lifting capacity

Working pressure

Cylinder stroke

Cylinder diameter

approximate mass

	AB600	AB601	AB602
mm	970	970	970
mm	1250	1250	1250
mm	810	810	810
mm	1125	1125	1125
mm	1620	1620	1600
mm	1130	1130	1130
mm	970	970	970
mm	1100	1100	1100
mm	1150	1150	1150
N.P.T	3/8"	3/8"	3/8"
kg	1900	1900	1900
MPa	18-22	14-18	11,5-14
mm	110	110	110
mm	100	110	125
kg	200	210	215

Low leakage, long life high pressure seals

Long cylinder rod guide

Long lasting replaceable pivot and cylinder bearings

All pivot points equipped with grease nipples

Cylinder has hard chromed shaft to international standards

Leg centralizing system

Very strong, yet light, high tensile steel frame